



Single Channel Impeller - 76mm passage

Model **DML**

**Submersible Sewage Pumps**

Submersible sewage pumps with single channel non-clog impellers and double row lower bearings for reliability. Suitable for raw sewage, waste water, storm water, etc.

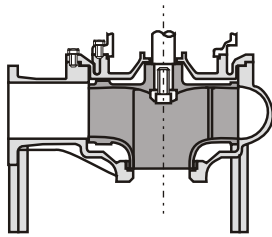

**Impeller Type & Solids Handling**



**Specifications**

Submersible sewage pump with non-clog, single channel impeller  
 Maximum solids handling: 76mm  
 Maximum liquid temperature: 40°C  
 Maximum submergence: 8m

**Materials**

Pump casing: Cast Iron  
 Impeller: Cast Iron  
 Suction cover: Cast Iron  
 Shaft : 403 Stainless Steel  
 Motor frame: Cast Iron  
 Fasteners: 304 Stainless Steel  
 Mechanical seal: Double mechanical seal in oil lubricated chamber, Silicon Carbide lower faces, Carbon/Ceramic upper faces.

**Motor Data**

Air filled, dry submersible, 4 pole motor  
 Y-Δ Star-Delta Starting (DOL for 2.2 kW only)  
 Insulation class F  
 IP58 protection  
 3 phase, 415 Volt, 50 Hz

**Scope**

10 m of cable  
 Discharge elbow with companion flange,  
 Optional Quick Discharge Connectors available

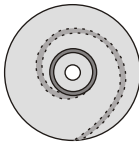

Enclosed Single Channel

Model	Ø	80	100	100
kW	All	All	All	All
Free impeller Passage (mm)		76	76	76

**Performance Curve**

Synchronous Speed: 1500 r.p.m.

Applicable standard of test : JIS B8301, B8302

**Model Code**

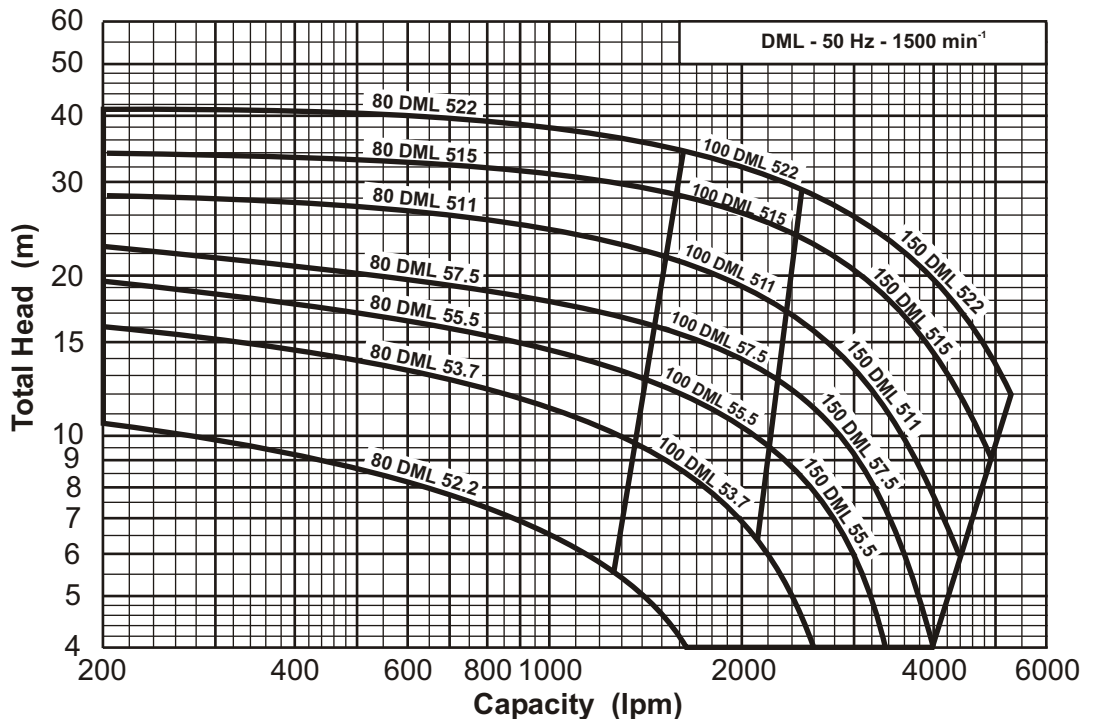
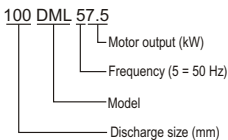

**Performance Table**

# Discharge size is determined by the elbow supplied with the pump.

Pump Model	Motor Output	# Discharge Ø mm	Full Load Current @ 415 V, 3ph.	Q= Capacity - litres/min														
				600	1200	1700	2400	2700	3000	3500	4000	4400	5000	5360				
				H=Total Head - metres (m)														
80 DML 52.2	2.2 kW	80 mm	5.2 A	8.2	5.6	3.6												
80, 100 DML 53.7	3.7 kW	80 or 100 mm	8.4 A	12.8	10.4	8.1	4.9	3.6										
80, 100, 150 DML 55.5	5.5 kW	80, 100 or 150 mm	12.7 A		14.0	11.5	8.8	7.1	5.8	3.5								
80, 100, 150 DML 57.5	7.5 kW	80, 100 or 150 mm	16.9 A		16.8	14.8	12.0	10.7	9.3	6.8	4.0							
80, 100, 150 DML 511	11.0 kW	80, 100 or 150 mm	23.0 A		23.6	20.8	16.8	15.0	13.3	10.8	8.2	6.4						
80, 100, 150 DML 515	15.0 kW	80, 100 or 150 mm	30.0 A		29.6	27.1	23.6	21.9	20.3	17.3	14.5	12.2	8.8					
80, 100, 150 DML 522	22.0 kW	80, 100 or 150 mm	42.0 A		36.1	33.5	29.8	27.9	26.0	22.8	19.4	17.4	14.0	12.0				

# Sectional Drawing

Model **DML**

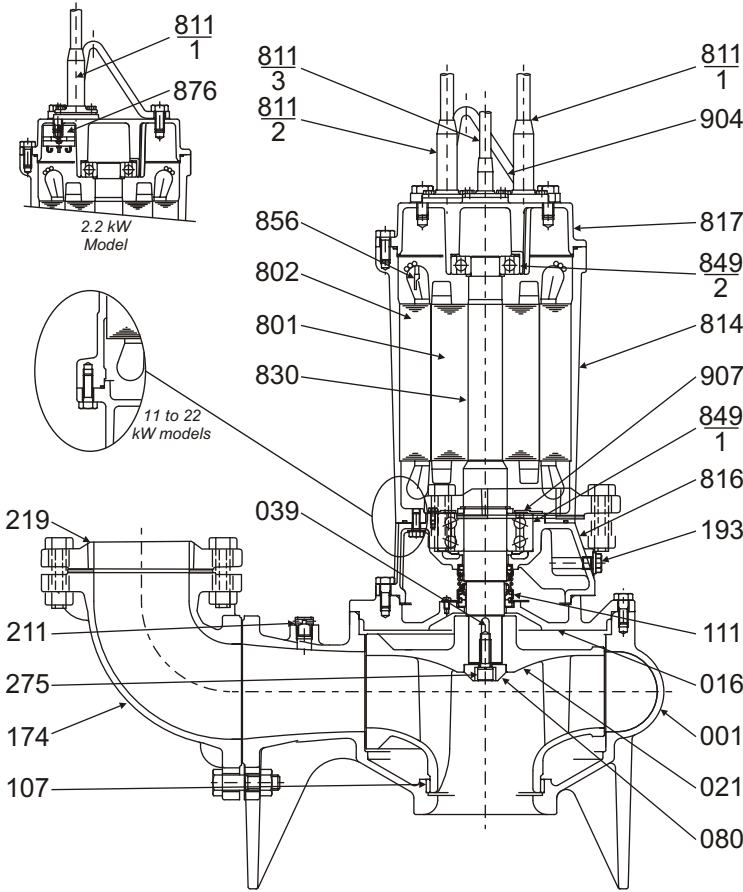

Item Number	Description	Material	Quantity per unit
001	Casing	FC200 Cast iron	1
016	Mechanical Seal Cover	FC200 Cast iron	1
021	Impeller	FCD400 Graphite Cast iron	1
039	Impeller Key	SUS304 Stainless Steel	1
080	Bushing	SS Steel	1
107	Wear Ring	BC Bronze	1
111	Mechanical Seal	Silicon Carbide lower faces Carbon vs Ceramic upper faces	1
174	Discharge Elbow	FC200 Cast Iron	1
193	Oil Plug	SUS Stainless Steel	1
211	Air Vent Valve	C3604 Brass	1
219	Companion Flange	FC200 Cast Iron	1
275	Impeller Bolt	SUS304 Stainless Steel	1
801	Rotor		1
802	Stator		1
811-1	Cable	4 core power cable	1
811-2	Cable	3 core power cable (except 2.2 kW)	1
811-3	Cable	2 core protector cable (except 2.2 kW)	1
814	Motor Frame	FC150 Cast iron	1
816	Lower Bracket	FC150 Cast iron	1
817	Upper Bracket	FC150 Cast iron	1
830	Shaft #	SUS403 Stainless Steel	1
849-1	Ball Bearing	Double Row lower bearing	1
849-2	Ball Bearing		1
856	Thermal Protector	(except 2.2 kW)	1
876	Auto Cut	(only 2.2 kW)	1
904	Lifting Hanger	SS Steel	1
907	Bearing Cover	SPCC Steel	1

# refers to pump side of shaft material

# Dimensions

Model **DML**

Units: mm unless otherwise specified

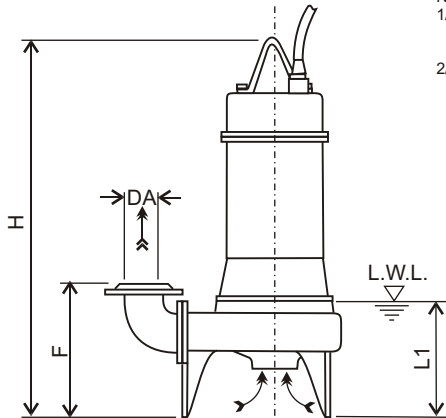

Note:  
1/. L.W.L. (Low Water Level) is limited to 10 minutes operation at low water level.  
2/. Is limited to 30 minutes operation with water level below top of motor.

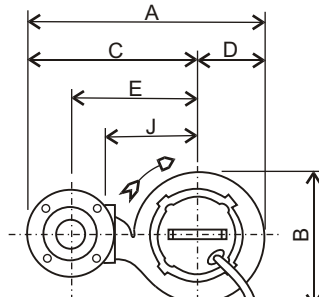

## Discharge Flange Dimensions (JIS 10kgf/cm<sup>2</sup>)

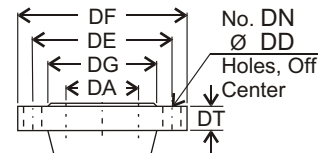

DA	DE	DF	DG	DT	DN	DD
80	150	185	126	18	4	15
100	175	210	151	20	8	15
150	240	280	212	22	8	19

## Discharge size is determined by the elbow supplied with the pump.

Submersible cable  
Length CL = 10 metres

Size DA	Model	Output KW	A			B	C			D	E			F			H	J	L1	Weight			
			800	1000	1500		800	1000	1500		800	1000	1500	800	1000	1500				800	1000	1500	
#	80 DML 52.2	2.2	534	-	-	320	378	-	-	157	285	-	-	298	-	-	668	210	279	80	-	-	
	80,100 DML 53.7	3.7	534	577	-	320	378	420	-	157	285	315	-	298	313	-	727	210	279	87	89	-	
	80,100,150 DML 55.5	5.5	640	653	713	381	453	465	525	188	360	360	385	334	369	824	255	310	118	121	127		
	80,100,150 DML 57.5	7.5	640	653	713	381	453	465	525	188	360	360	385	334	369	824	255	310	123	125	132		
	80,100,150 DML 511	11	734	746	806	455	513	525	585	221	420	420	445	350	350	385	938	315	329	157	160	166	
	80,100,150 DML 515	15	734	746	806	455	513	525	585	221	420	420	445	350	350	385	938	315	329	163	166	172	
80,100,150 DML 522	22	777	790	850	497	533	533	605	245	440	440	465	363	363	398	1021	335	332	223	226	232		

Specifications subject to change without notice



EBARA PUMPS Australia Pty. Ltd

Data Sheet

DML 06-12