



Pump specifications:

Type.....BA200E D328
 Max. flow 700 m³/hour (3082 US GPM)
 Max. pressure 32 mwc (107 ft.)
 Connections..... DN 200 (8")
 Solids handling 80 mm (3,15")
 Impeller type Semi-open impeller
 Priming system BBA MP50
 Engine Perkins 1104D-44T
 Emission standard .. Stage IIIA / Tier 3
 Basic frame..... BS12-23
 Weight (net) Approx. 1820 kg (4000 lb.)

FEATURES

BA auto prime pump

The BA range of pumps has been designed with a clear focus on reliability, efficiency and durability. Featuring a 100% mechanical priming system, the BA series pumps quickly prime and re-prime, even from dry conditions. The heavy build style of both pump and canopy make the BA range perfect for use in the strenuous contractor market.

World-class performance

The BA range is built to be deployed on the most demanding dewatering and sewage bypassing applications. Using high efficiency pumps and state-of-the-art diesel engines, the pumps offer maximum performance at minimal cost, fully in-sync with the company philosophy of "Lowest cost of ownership".

Sustainability

- High efficiency pumps minimising fuel consumption
- Emissions in accordance with the regulations in all continents except Europe & North America
- Corrosion free hot dip galvanised frame
- 100% Oil-spill free priming system

Complete package designed & built by BBA Pumps

- Complete in-house design & production
- Over 60 years of experience in the market
- Complete testing facility in-house
- Contemporary & functional design
- Durable & eco-friendly materials
- Custom builds available

After sales service & product support

- Single supplier for parts, spares & accessories
- Dedicated customer help-desk (24h service)
- Dedicated service department in-house
- Global parts distribution network
- Optional global on-site servicing available
- Extensive training options available (technical & commercial), on-site or in-house



PERFORMANCE CURVES (1500 RPM)

Continuous duty according ISO 9906

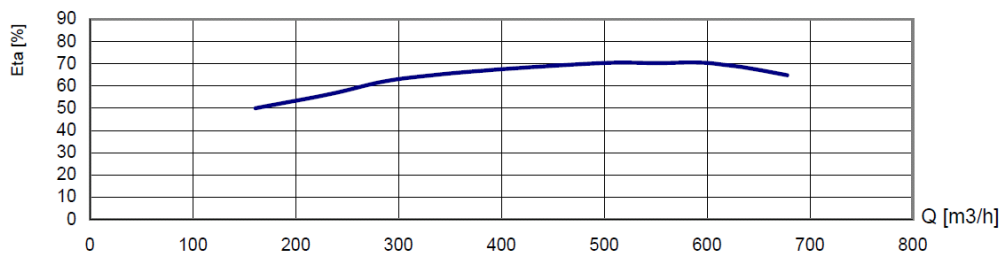
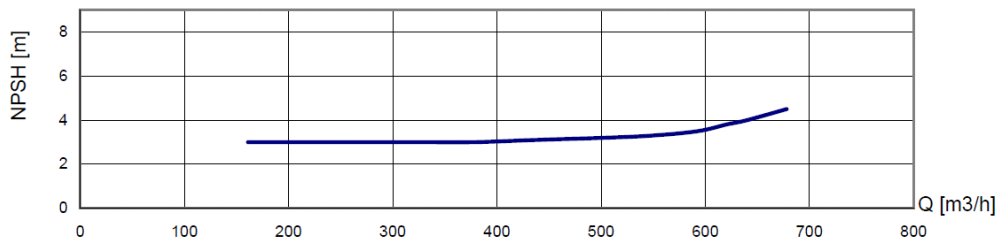
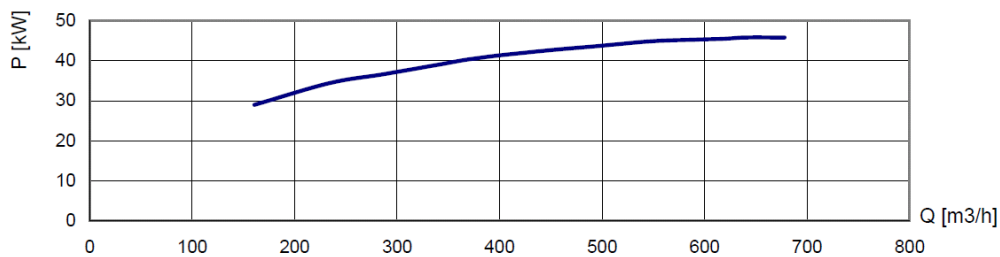
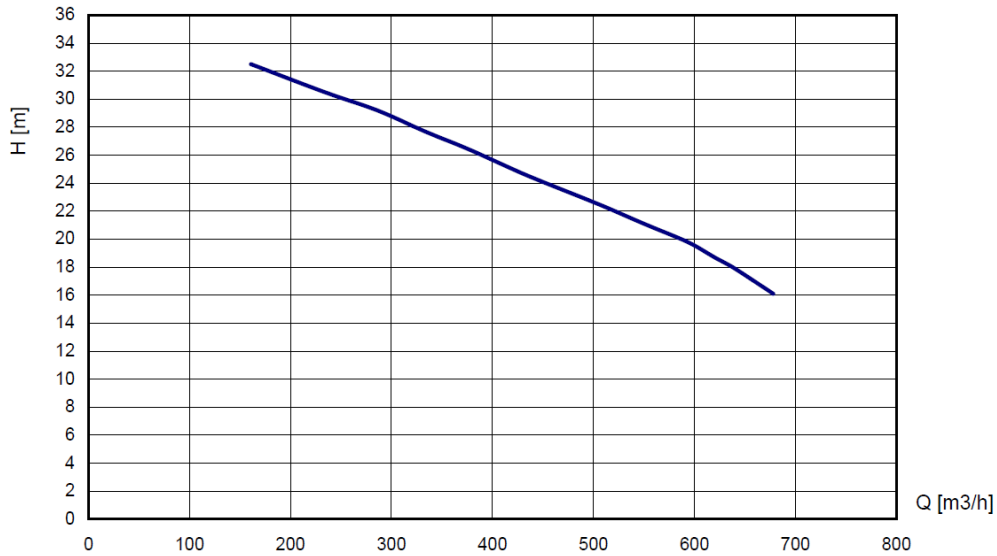

Engine speed rpm		Capacity Q in m ³ /h					Fuel consumption (BEP) l/h
		300	400	500	600	700	
1500	H mwc	28	25	23	20	14	13
1400		24	21	20	17	12	10
1300		20	18	17	14	10	8

STANDARD TECHNICAL SPECIFICATIONS

BBA auto prime pump

Pump type.....	BA200E D328
Max. flow.....	700 m ³ /hour (3080 US GPM)
Max. head.....	32 mwc (107 feet)
Impeller type.....	Semi open impeller
Solids handling.....	80 mm (3.15 inch)
Pump casing.....	Cast iron GG20
Impeller.....	Chrome Moly 42CrM04
Wear plate.....	Chrome Moly 42CrM04
Pump shaft.....	C45
Shaft seal.....	Mechanical seal 60 mm (2.36 inch)
Seal faces.....	Tung/Sic
Seal rubbers.....	Viton



BBA priming system

Pump type.....	BBA MP50 Diaphragm pump
Air handling capacity.....	50 m ³ /h (30 CFM)
Max. vacuum.....	8.5 m (29 inHg)
Drive.....	Toothed belt (continuous drive)
Float box.....	Aluminium
Non return valve.....	Cast iron GG25
Check valve disc.....	Buna-N

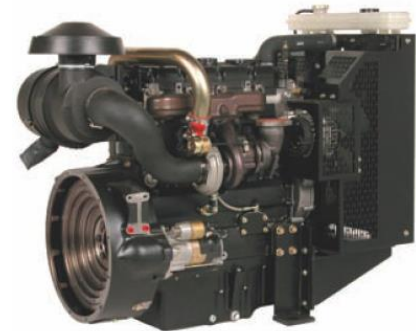

Engine

Engine brand.....	Perkins
Engine type.....	1104D-44T
Flywheel power.....	53 kW (72 Hp)
Max. engine speed.....	1500 RPM
Fuel consumption.....	234 g/kWh
Displacement.....	4.4 l
Number of cylinders.....	4
Cooling system.....	Water cooled
Exhaust emission EU.....	Stage IIIA
Exhaust emission US.....	Tier 3

BBA dashboard LC20

- Auto start/stop system
- Two float switches included (10m cable)
- Switch Manual-0-Auto
- Tachometer
- Hour counter
- Warning lights "oil and engine temperature"
- Warning light "auto stand-by"



Fuel system

- Steel fuel tank 100 L. net (26 US Gallon)
- Fuel tank cap Ø 100 mm
- Mechanical fuel injection system
- Fitted with water separator & extra in-line fuel filter

Electrical system & safety features

- Nominal voltage 12 Volt
- Premium quality battery
- Low oil pressure shut down
- High temperature shut down

BASIC FRAME

BBA open diesel unit

- Frame model.....BS12-23
- Dimensions L x W x HApprox. 2270 x 1170 x 1640 mm (without connections)
- Dimensions L x W x HApprox. 89.4 x 46 x 64.5 inch (without connections)
- Basic frame.....Hot dip galvanised
- Fuel tank.....Steel net 100 ltr (26 US Gallon)
- Fuel tank cap.....100 mm (4 inch)
- Lifting point.....Fitted with single lifting point
- Forklift pockets.....Fitted with 2 forklift pockets
- Exhaust system.....Exhaust is mounted on the engine
- Connections.....Please consult “auxiliary items”
- Documentation box.....BBA user manual and BBA warranty book

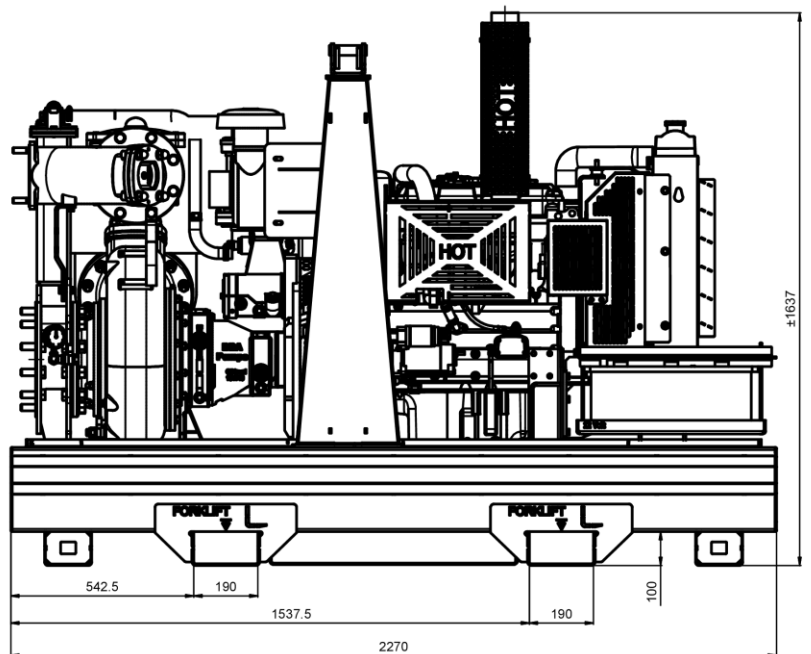
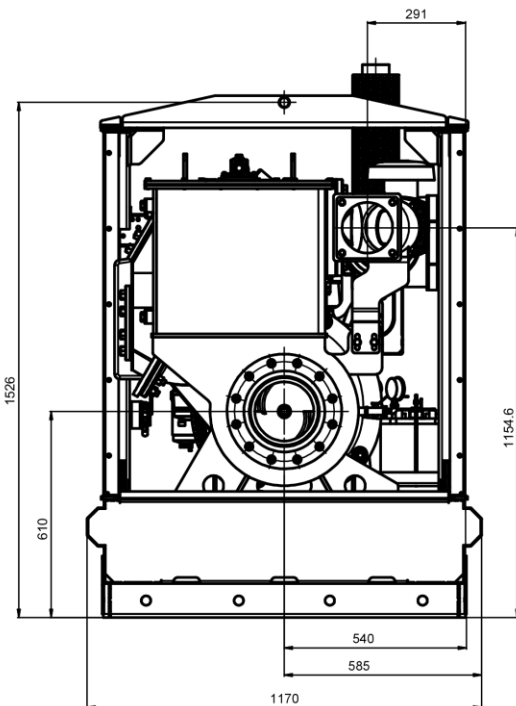

Actual dimensions (in mm) may vary depending on selected quick couplings.



Semi-open impeller
Corrosion and abrasion resistant Chrome Moly (42CrM04) alloy.



Priming system
Diaphragm pump, air-cooled, water-resistant and oil-spillage free. Air capacity of 50 m³ per hour.



Easy inspection
Oil glasses, drain valves and fill plugs all easily accessible.



Large inspection covers
Easy access to float box, impeller and non-return valve.



4 Year limited warranty
The BBA limited warranty covers years or operating hours whichever occurs first. For more details please consult the BBA warranty book.

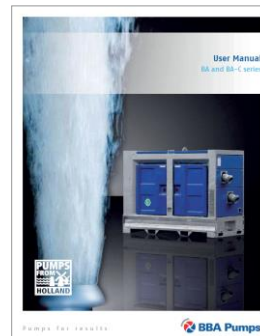

User Manual BA and BA-C
Extensive user manual with important information concerning the pump unit, pump installation and safety warnings. Available in several languages.

Pictures used are for illustration purposes only.